

# Balboa 32U4 Control Board

## ATmega32U4 pinout and peripherals

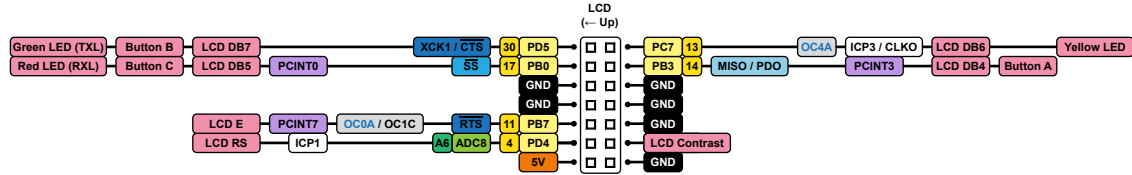

- 5 V logic
- Power distribution
  - Ground (0 V)
  - AVR I/O pin names
  - Arduino digital pin numbers
  - AVR ADC channels
  - Arduino analog pin numbers
  - USART
  - PC
  - SPI
  - JTAG
  - PWM outputs (Arduino analogWrite)
  - Interrupts
  - Other peripheral functions
  - On-board hardware

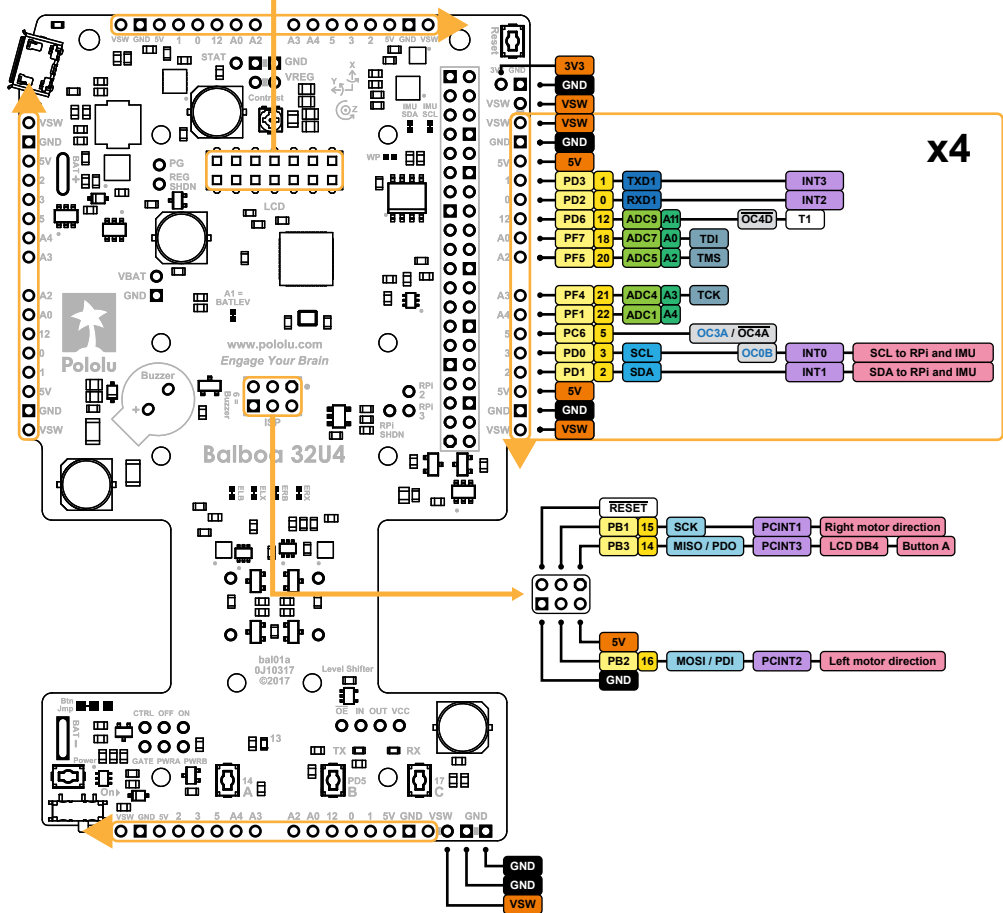

# Balboa 32U4 Control Board

Raspberry Pi pinout and peripherals, level shifter, and board power control

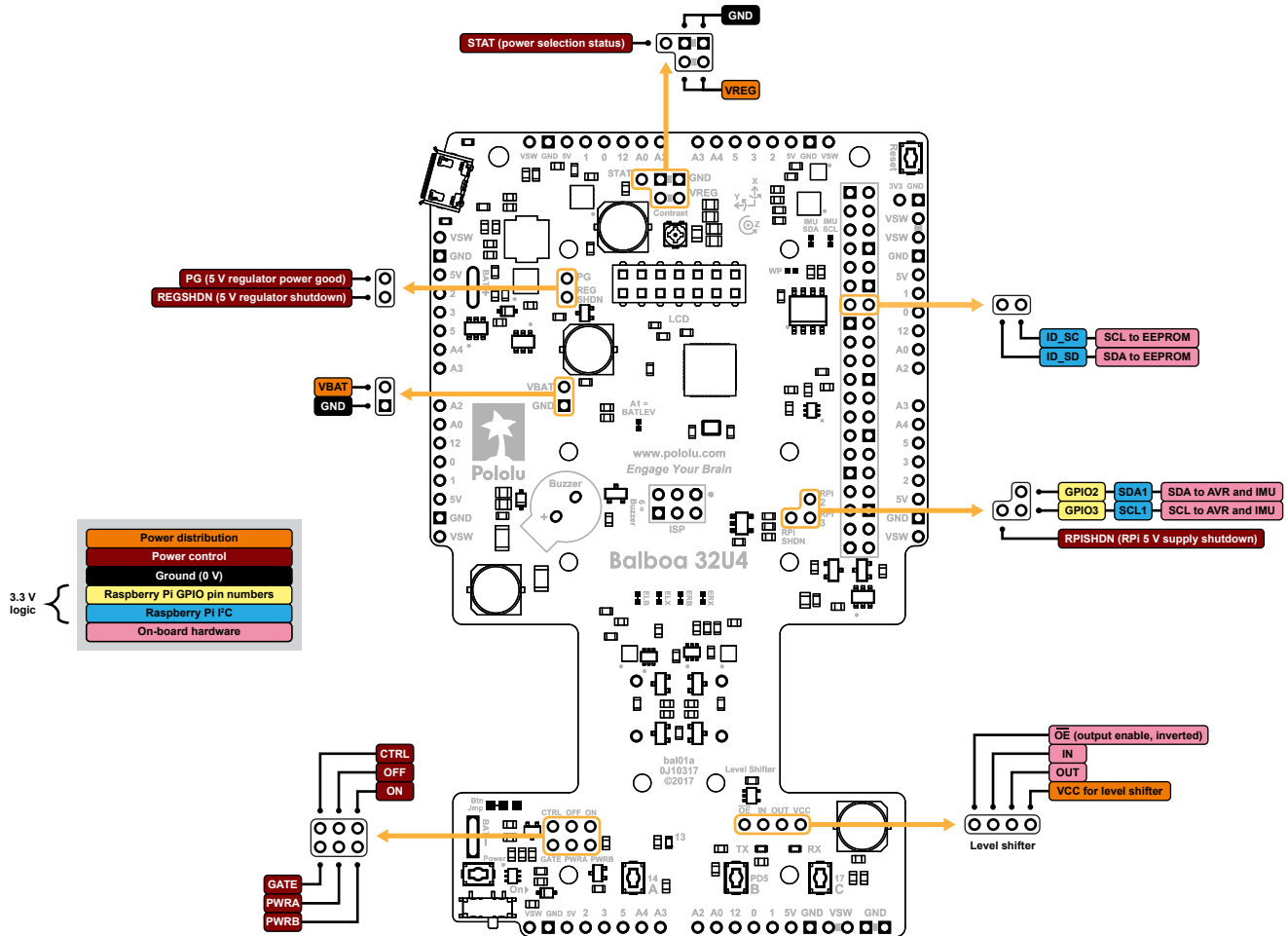

# Balboa 32U4 Control Board

## Power distribution

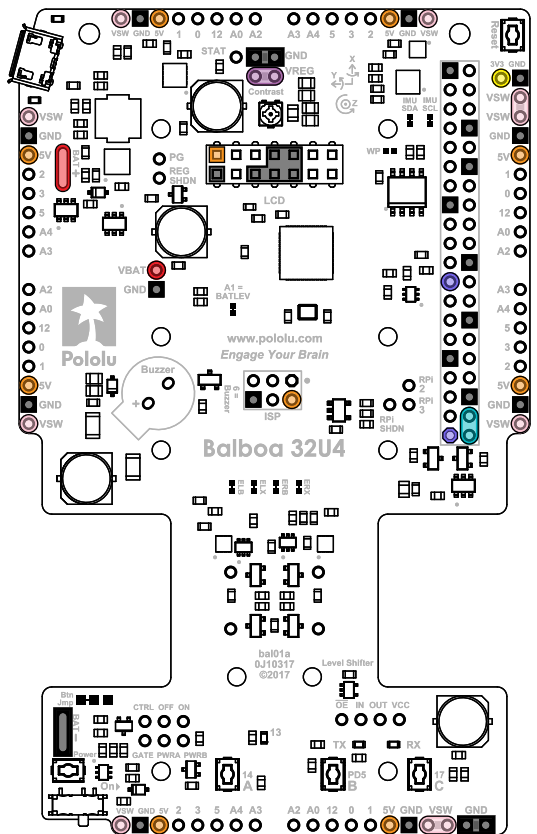

Ground (0 V)
VBAT (BAT+)
VSW (after switch)
5V (VCC access)
VREG (5 V regulator output)
RPI5V (RPI 5 V access)
RPI3V3 (RPI 3.3 V output)
3V3 (3.3 V regulator output)